

Ideas & experiences applying Adaptation Pathways and Multi-Layer Safety concepts in practice



Andrew Warren
*with Herman van der Most
& Karin de Bruijn*

Odense, 4th April 2019



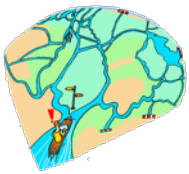

Why Adaptation Pathways?



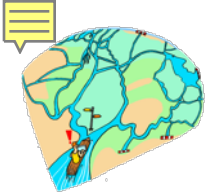

Potential Futures



A yellow diamond-shaped sign with a black border and the words "CHANGE AHEAD" in bold black capital letters. The sign is tilted slightly to the right. The background is a dark blue gradient.

Uncertainty

Decision are made now

Decisions are made over time in interaction with the system and cannot be considered independently

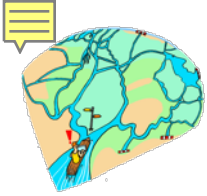

What to do?

Not too much or too little

When to do it?

Not too early or too late

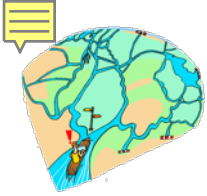

Challenges of long-term planning



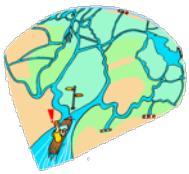

What is the adaptation pathways approach?
(Dynamic Adaptive Policy Pathways)



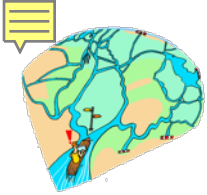

Dynamic Adaptive Policy Pathways (DAPP)

Decisions are made over time in dynamic interaction with the system and cannot be considered independently.

- A DMU approach that explicitly considers decision making over time and the sequencing of decision (pathways).
- Supports planners to design a dynamic adaptive plans: short-term actions, long-term options, adaptation signals.
- Fusion of **adaptive policymaking** (Kwakkel et al. 2010; Walker et al. 2001), **adaptation tipping points** (Kwadijk et al. 2010) and **adaptation pathways** (Haasnoot et al. 2012).

“Many roads lead to Rome”

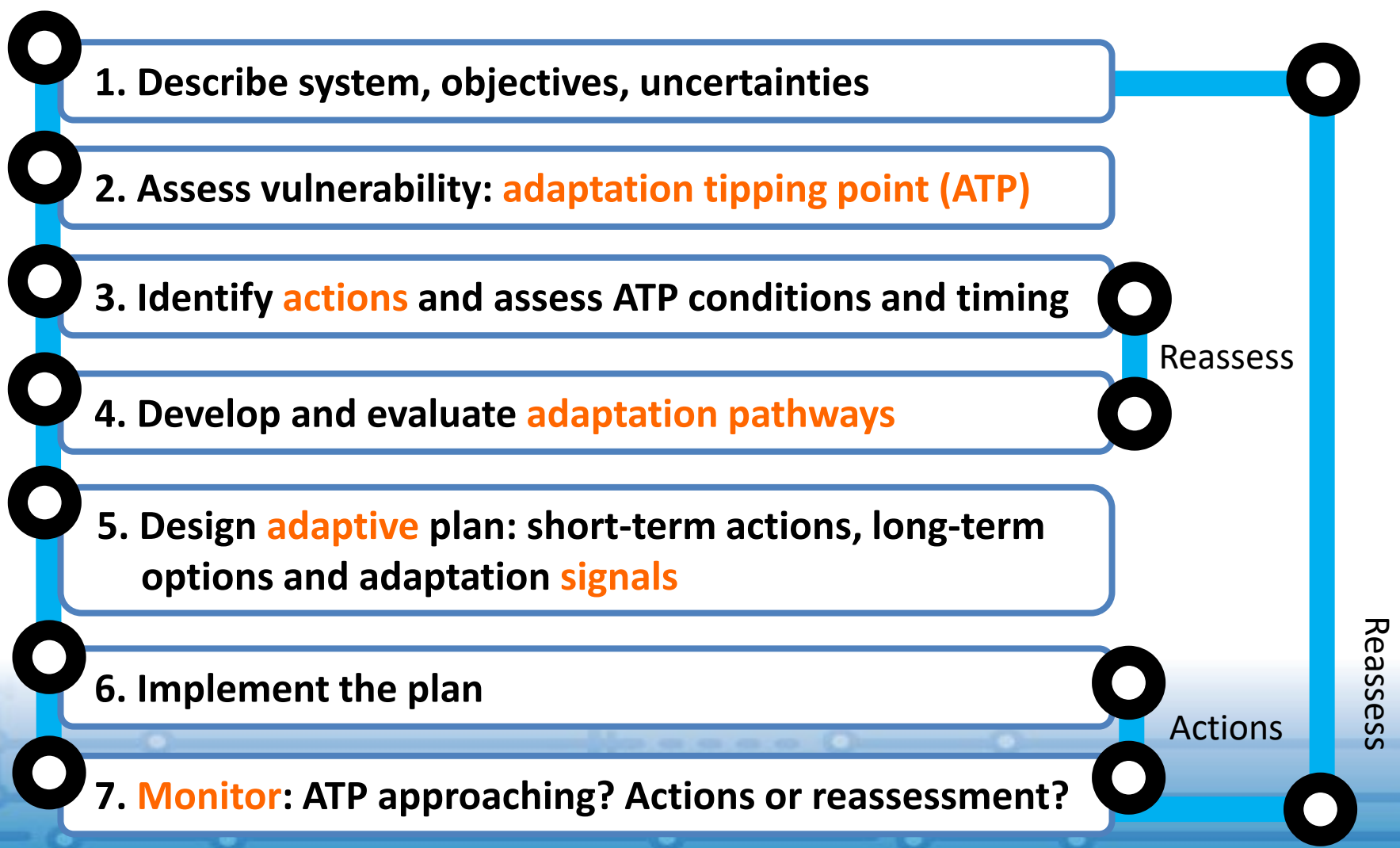

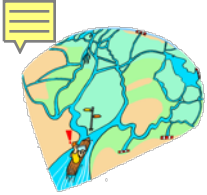

Adaptation Tipping Points

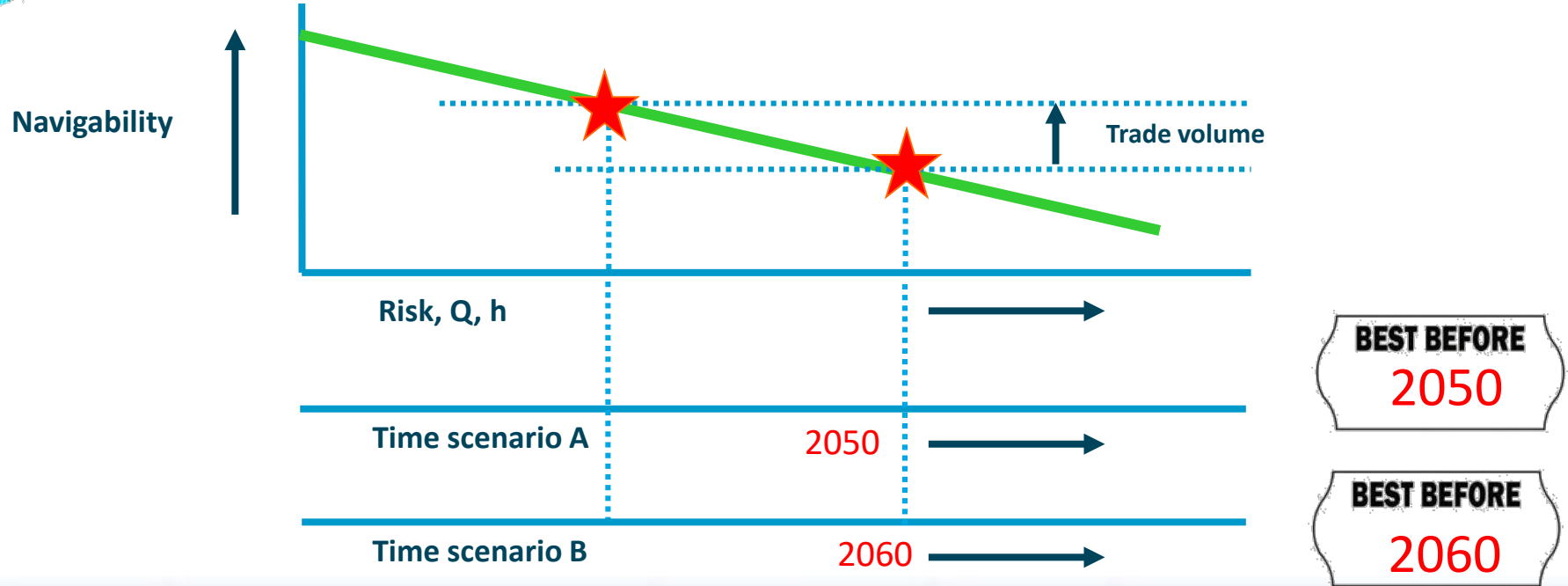

Decision moment = f (time A, time B, lead time action)

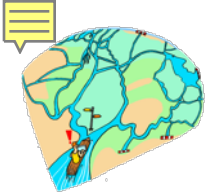

Adaptation Pathways Map

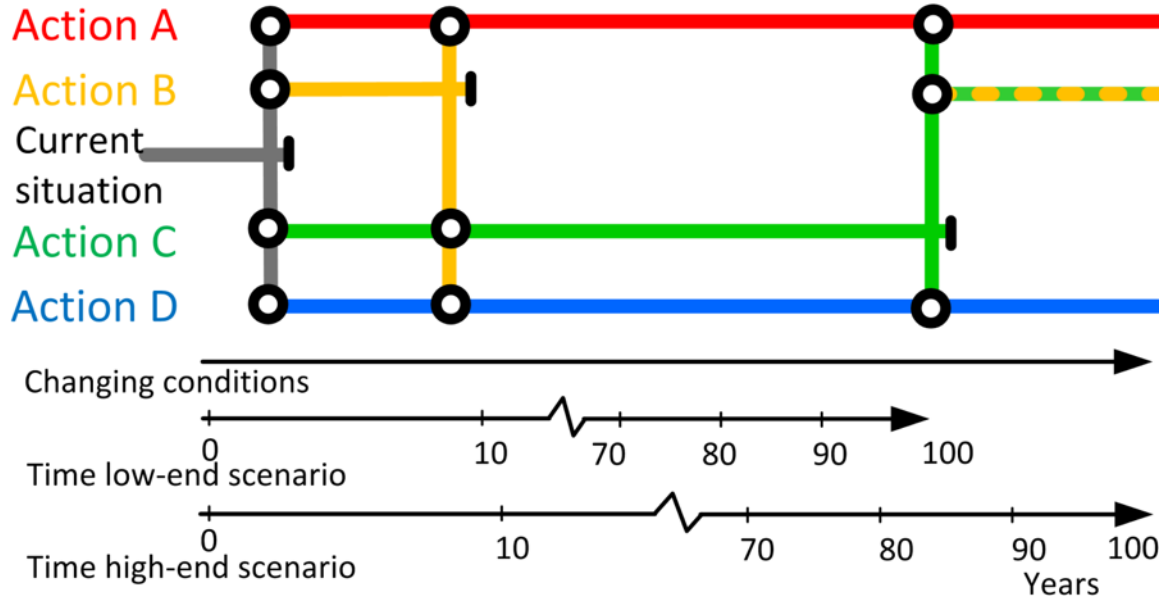

Time horizon 100 years

Pathway	Costs	Benefits	Co-benefits
1	+++	+	0
2	+++++	0	0
3	+++	0	0
4	+++	0	0
5	0	0	-
6	++++	0	-
7	+++	0	-
8	+	+	---
9	++	+	---

- Transfer station to new policy action
- Adaptation Tipping Point of a policy action (Terminal)
- Policy action effective

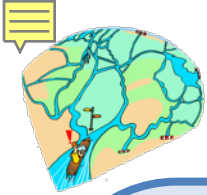

Why use DAPP?

To make smarter investment decisions by accounting for long-term uncertainties and making explicit the time-related limitations of actions.

To connect short term targets with long term goals by identifying no-regret short term actions that meet objectives but also avoid future lock-ins.

When to use DAPP?

When dealing with persistent, and uncertain problems that are characterised by complex interactions of broad societal trends and physical processes and that involve many stakeholders with different perspectives.

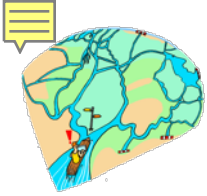

DAPP and pathways particularly useful when dealing with:

- **Long-term** planning horizon (50+ years)
- System “failure” leading to **high impacts**
- System **sensitivity** to changing conditions
- High potential for investment ‘**regret**’
- **Path-dependency** or ‘transfer cost’ risks
- **Temporal** or **scenario dependencies**
- Future implementation **sensitivity** to changing conditions

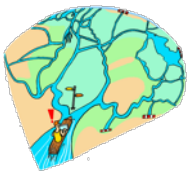

Doing DAPP





Common assumptions about DAPP/DMDU

**Detailed
Analysis**

**Data
Intensive**

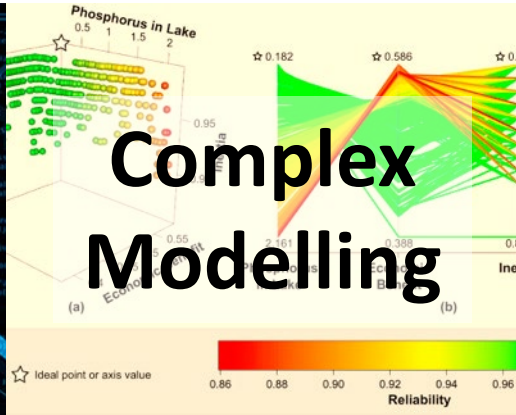

**Many
Model
Runs**

Confusion

Costly

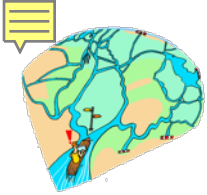

Phased approach to DAPP

Level III Analysis

- Refinement of analysis using fast integrated system model (e.g. exploratory modelling of all portfolio combinations)

Level II Analysis

- Preferred portfolio selected for assessment with available information or a (simple) model → ATP
- Manual pathways built together with stakeholders (smart selection of preferred pathways)

Level I Analysis

- Qualitative descriptive assessment
- Pathways narratives

Awareness Raising

- Serious gaming
- Introduction to adaptive planning methodology

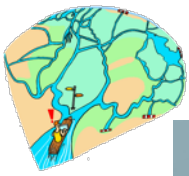

1. Awareness Raising



A **serious game** to help participants **learn** about **adaptive planning** and **preparing for an uncertain future**.

Participants **experience futures** that trigger **'aha' moments** and **discussions** about how to better develop adaptive long term strategic plans.

Deltares

Play Sustainable Delta



2. Level I Scoping Assessment

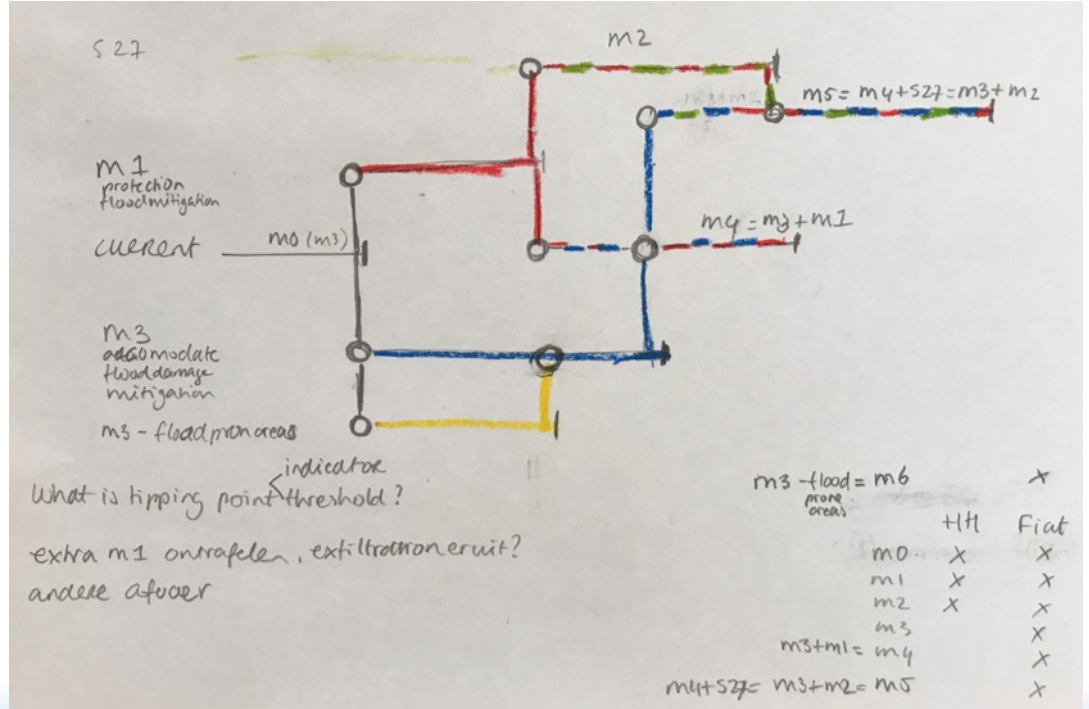

2-day scoping workshop: Initial vulnerability assessment and narrative pathways

3. Level II Initial Study

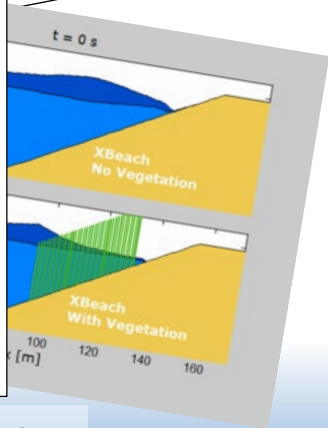
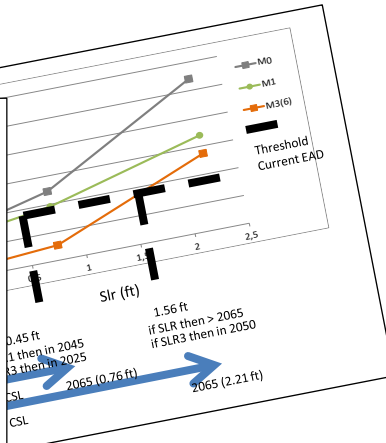
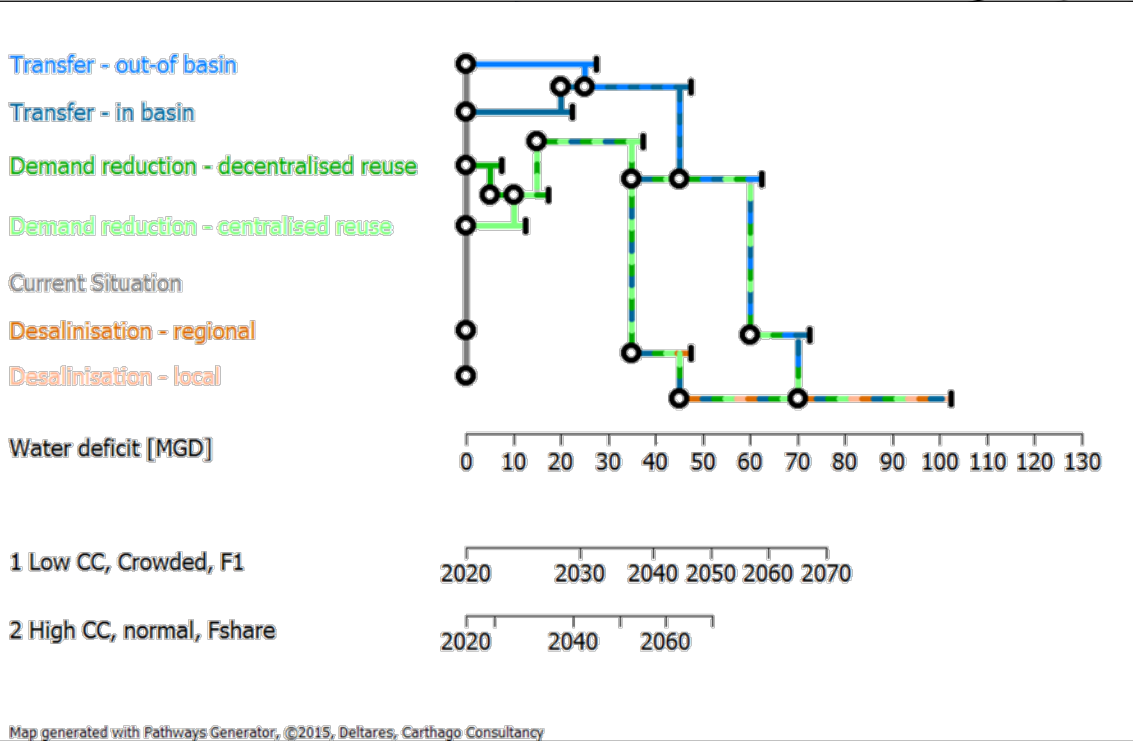
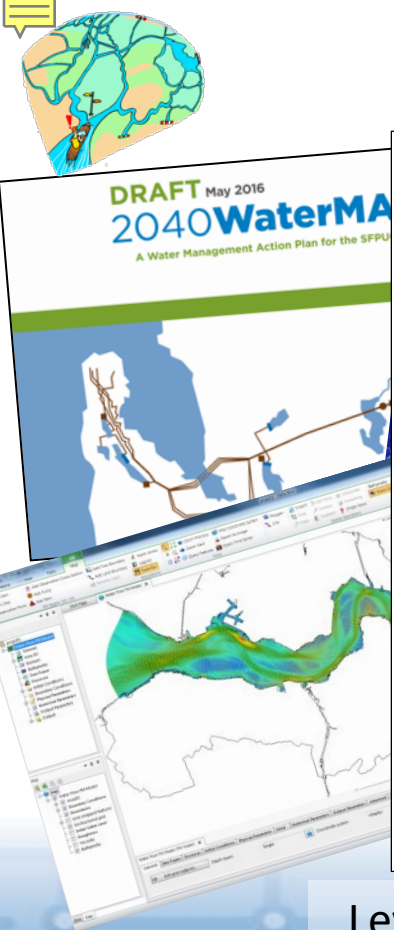

Level II: Initial study using available information/simple models



4. Level III Full Exploratory Assessment

Using a Fast Integrated System Model / Metamodel

FISMs integrate and simplify interactions and relevant feedbacks among **complex systems** into **fast, low-resolution models** (for example in Microsoft Excel, or python) necessary for high-level reasoning and communication, exploratory analysis and uncertain long-term decision support. Permit implementation of interrelated DMDU approaches, such as:

→ Robust Decision Making (Lempert et al, 2013)

→ Decision Tree Framework (i.e. decision scaling) (Ray & Brown, 2015)

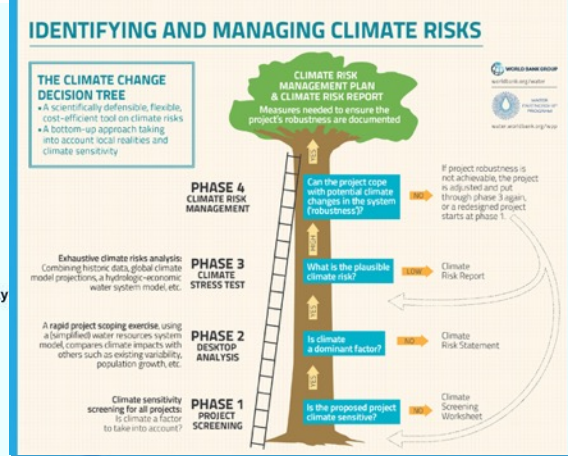
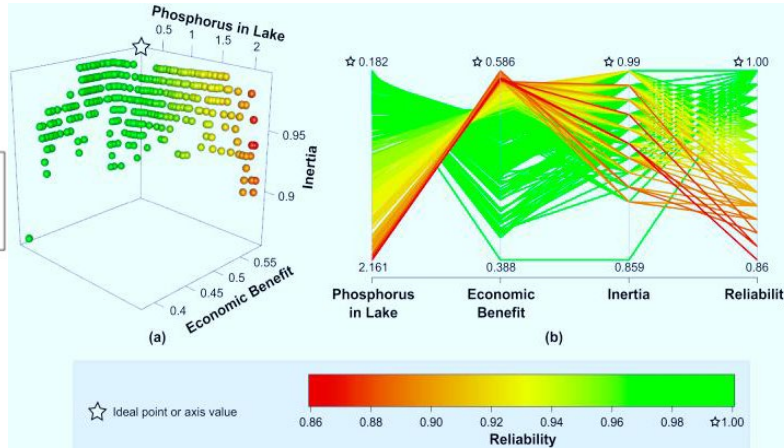
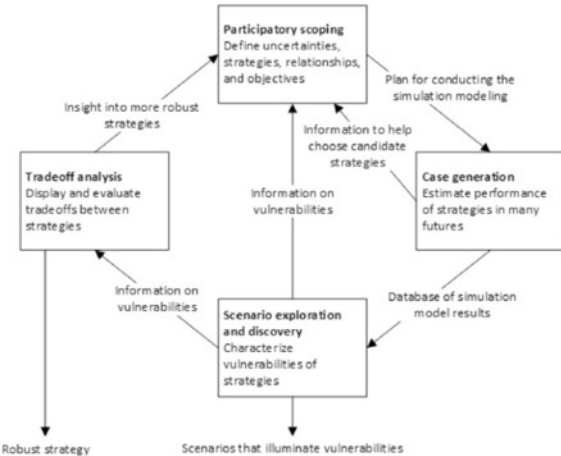



4. Level III Full Exploratory Assessment

Using a Fast Integrated System Model / Metamodel

- Not intended to replace complex modelling for detailed design of options
- Integrates and simplifies outputs from multiple complex models to enable exploratory assessment
- Mimics the performance of the detailed complex models, whose outputs are used to calibrate metamodel performance (within acceptable range of calibration, e.g. 80-90%)
- Yields (strategic) decision support outputs via accessible dashboards

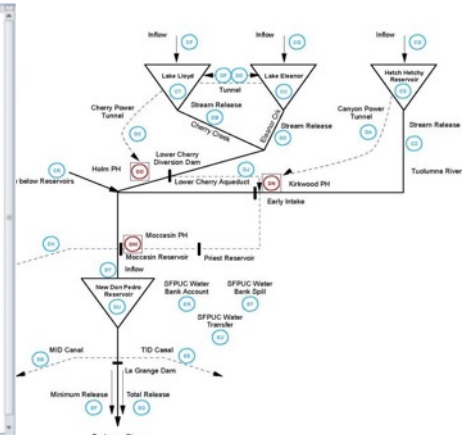
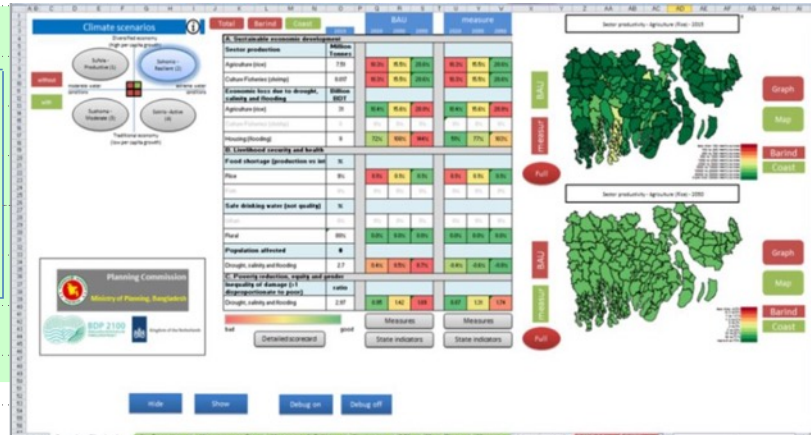
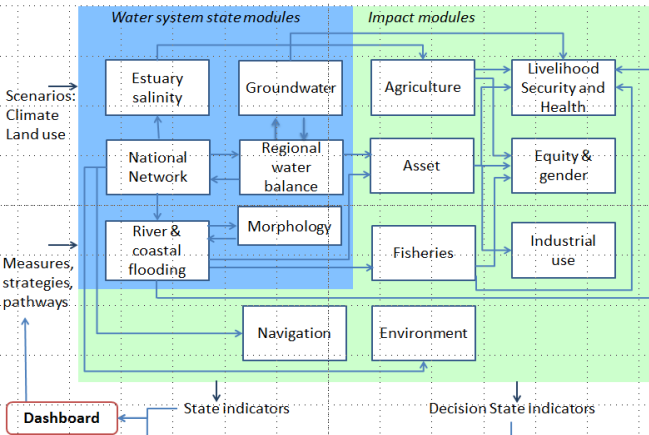

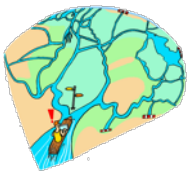

DAPP: Some Coastal Applications



RISES-AM: Sandy Coasts (Holland)

Challenge: Diminishing coastline due to sea level rise



- Densely populated coast
- Widely available and accessible sand resources
- Flexible phasing of sand nourishment as required

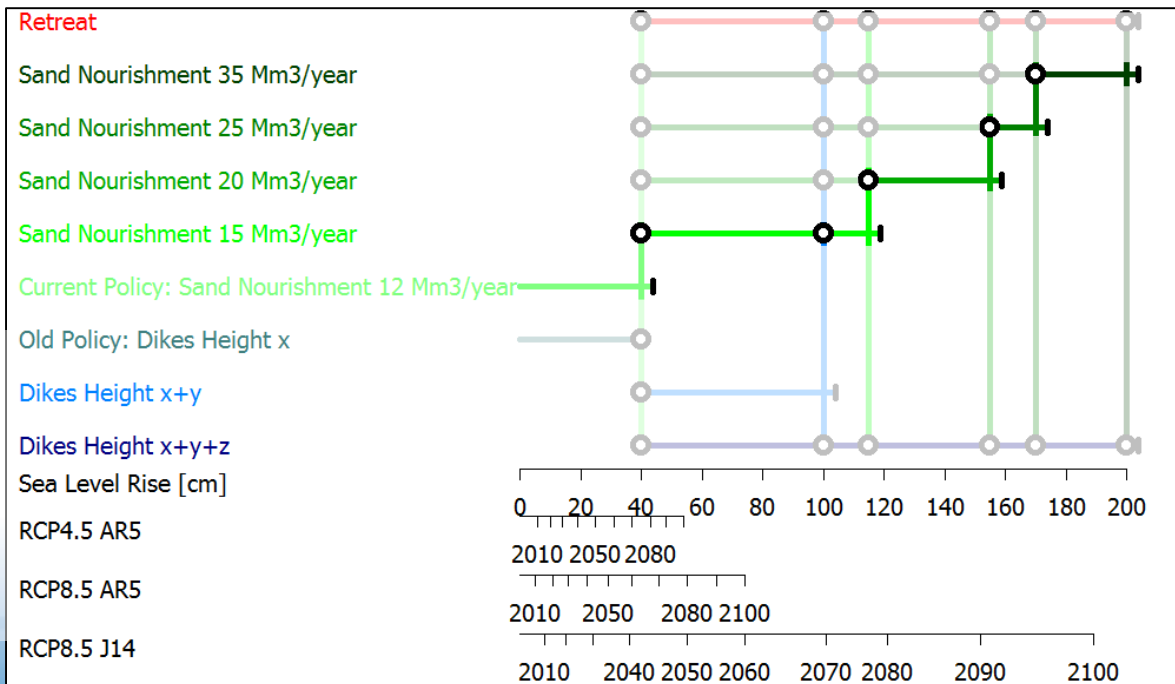

RISES-AM: Sandy Coasts (Aveiro, Portugal)

Challenge: Diminishing coastline due to sea level rise



- Sparsely populated coast
- Limited accessible sand resources available
- Localised nourishment at population centres, or retreat.

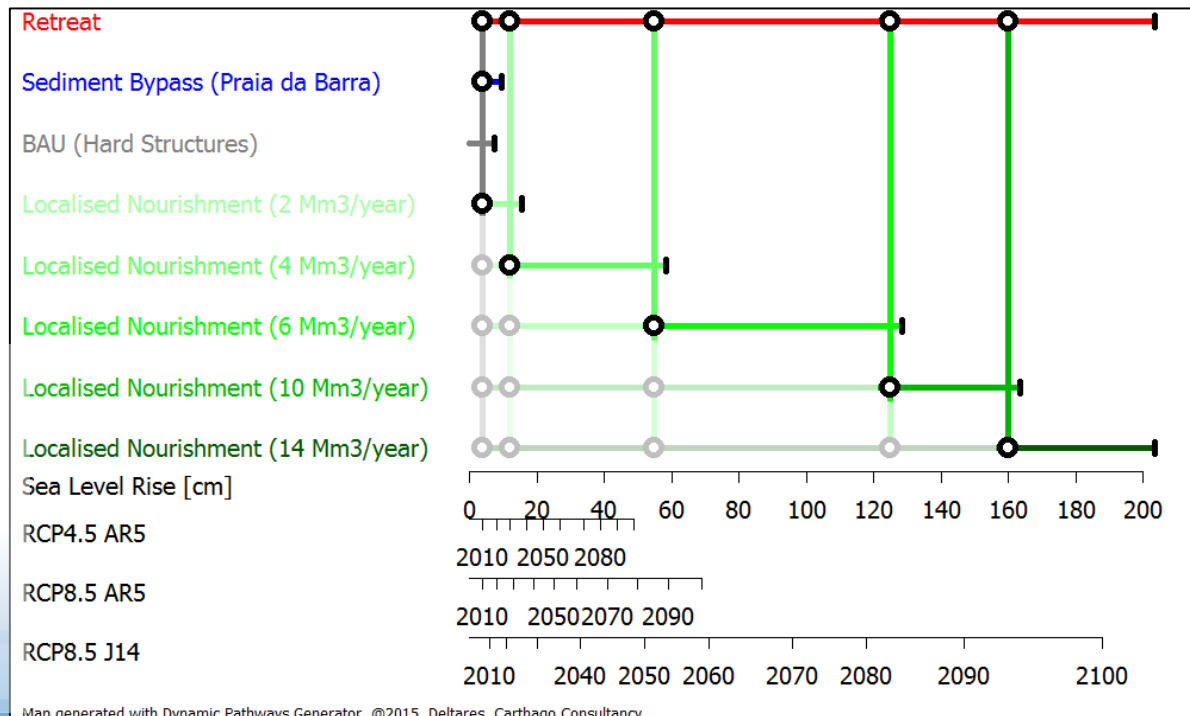

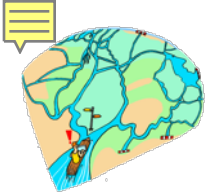

Miami FRM, FL

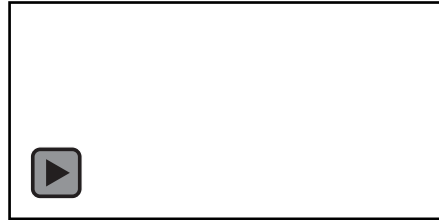
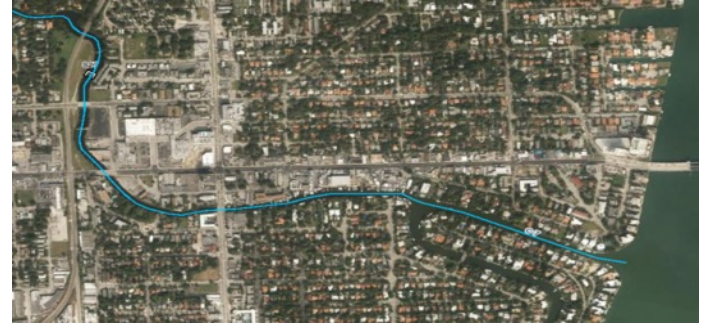
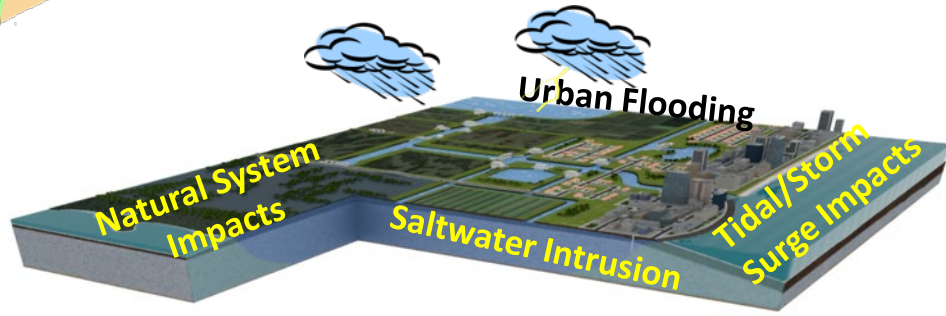

Assessment of alternative flood mitigation strategies for C7-Basin in Miami, Florida

System vulnerable to sea level rise due to:

- Low topography
- High groundwater table
- Sandy soils and porous limestones
- Complex water management system (i.e. governance)

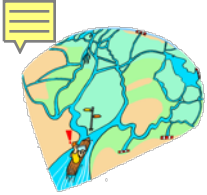

Miami FRM, FL



Assessment of alternative flood mitigation strategies for C7-Basin in Miami, Florida

Options assessed:

M1 – Local flood mitigation: flood walls, exfiltration trenches, flap gates, and local pumps

M2 – Regional flood mitigation: forward pumps at S-27 coastal structure (small & large pumps)

M3 - Land-use mitigation: raise roads and buildings to 6, 7 or 8 feet elevation

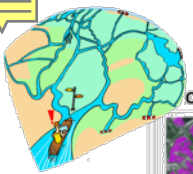

Miami FRM, FL

ATP assessment carried out with simple modelling using Delft-FIAT

Preferred pathways developed
→ Local/regional mitigations can buy some time, but land-use measures ultimately necessary.

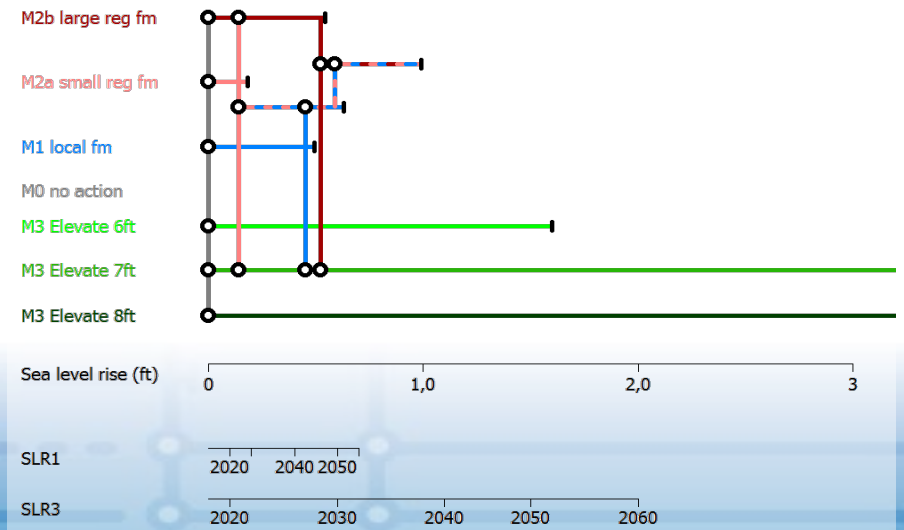
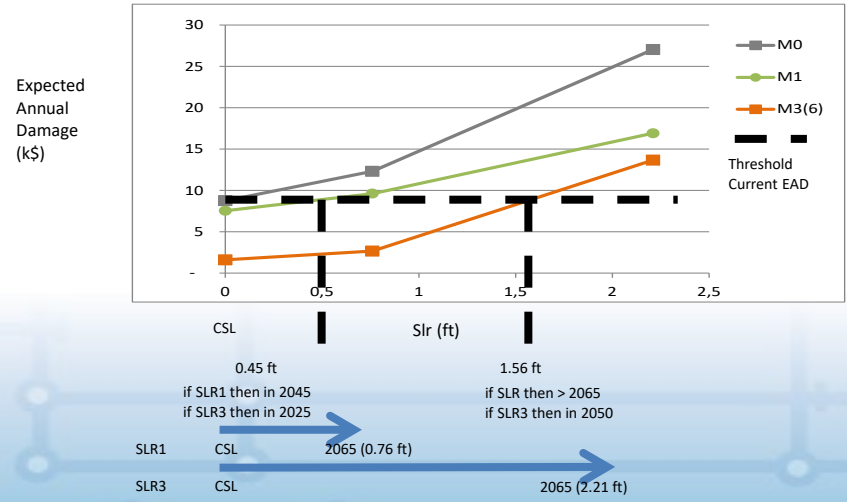
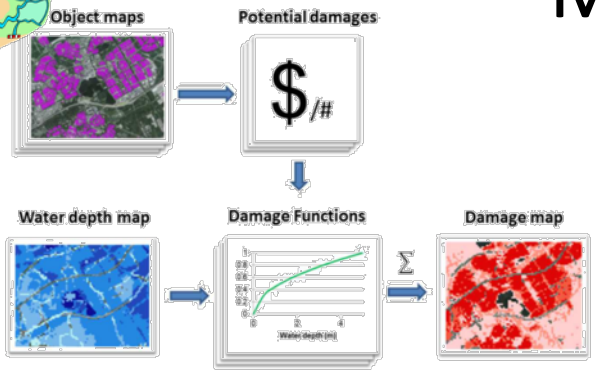

Hutt River, New Zealand

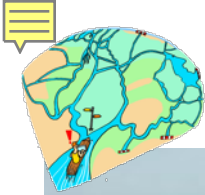

Coastal flood protection levels of service (LoS) vulnerable to storm surges and sea level rise

Objective: Upgrade existing flood defence system to 1:440 year protection level and maintain this LoS for at least 100 years.

Current 1:440 discharge = $2,300 \text{ m}^3/\text{s}$

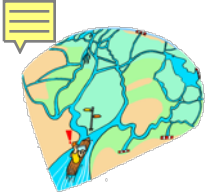

Hutt River, New Zealand

Variation in Level of Service/Protection levels

Orange can be upgraded at minimum cost

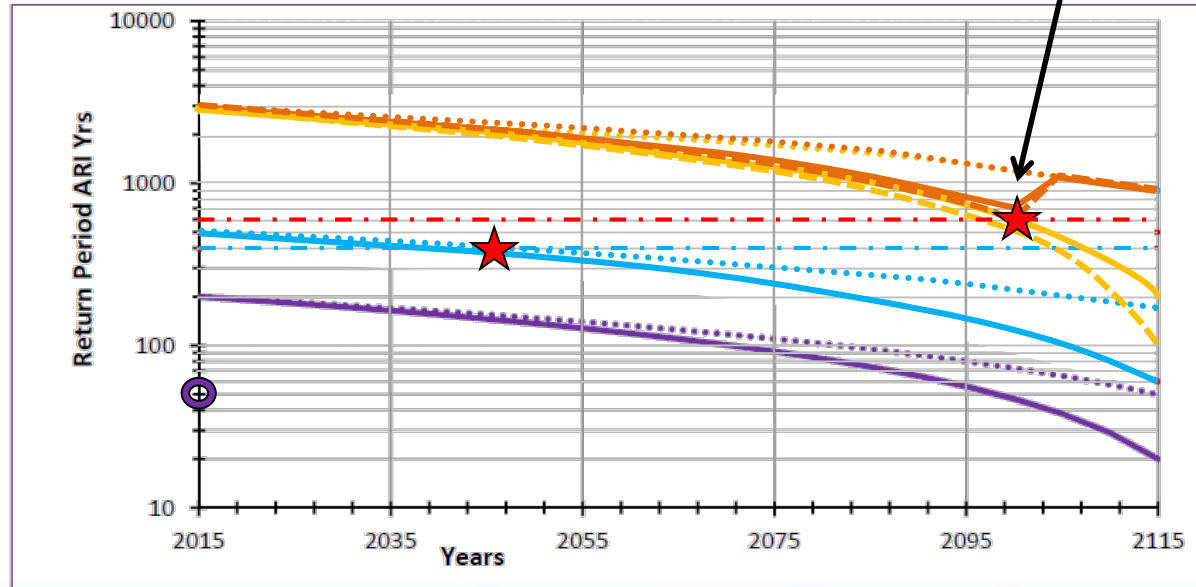

Estimated Use by Date



Option 1: Orange 2100 (can be upgraded at min cost)

Option 2C: Yellow 2100

Option 4: Blue 2045 (LoS drops to about 400 Yrs)

Option 5: Purple (well below acceptable LoS)

..... Low Emissions

———— High Emissions

- - - - High Emissions (high)

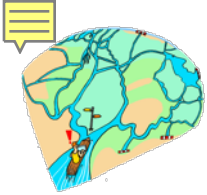

Hutt River, New Zealand

Option 1: Wide channel, wide berm and stopbanks (dikes) to meet standard until 2115 in all scenarios

Option 2C: Wide channel, narrow berm and immediate property acquisition

Option 4: Narrower channel, 30-years flood protection, property acquisition after 30 years

Option 1

Option 2C

Option 4

Existing situation

Discharge of 1:440 yr protection level (cumecs)

High Emissions (A2) median

High Emissions (A2) 90th percentile

Low Emissions (2°C) median

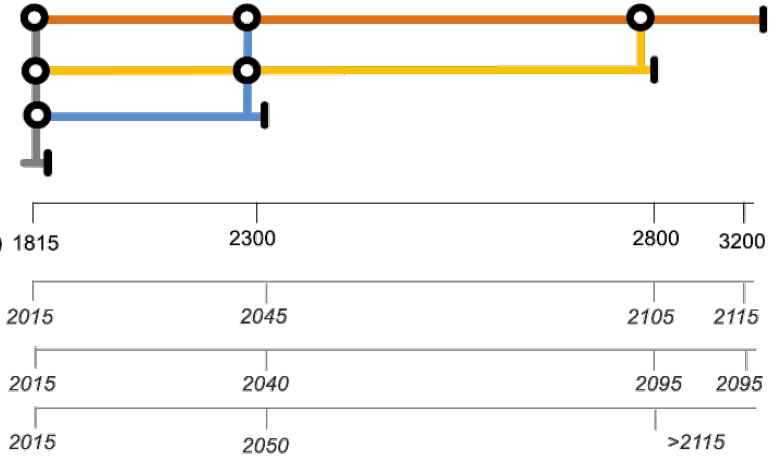

- Trigger (decision point) for policy action
- Adaptation Threshold
- Policy action effective

- Most actions needed in the end. Choice becomes: build now all at once or build in different phases. Scorecard supports decision making on this.
- Next step to consider other policy actions such as flood paths for residual risk/flood-proof building/planning controls/managed retreat.

Pathway	Main effects		Side effects		
	Relative Costs	Target effects	Social impacts	Transport impacts	Environmental impacts
1	\$\$\$\$	++	---	+++	++++
2	\$\$	+	---	++++	+++
3	\$\$\$\$	++	---	++++	++++
4	\$	-	0	++	+
5	\$\$\$	+	--	++++	+++
6	\$\$\$\$	++	---	+++	++++
7	\$\$\$\$\$	++	---	++++	++++

Lakes Entrance, Australia

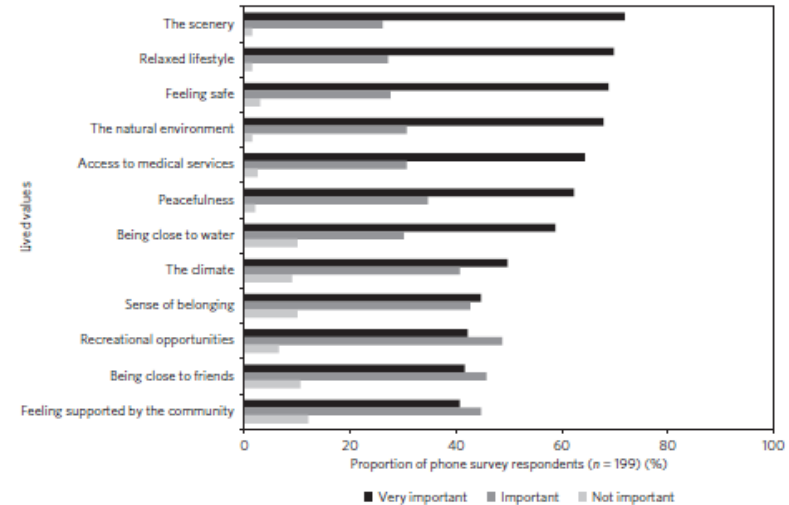
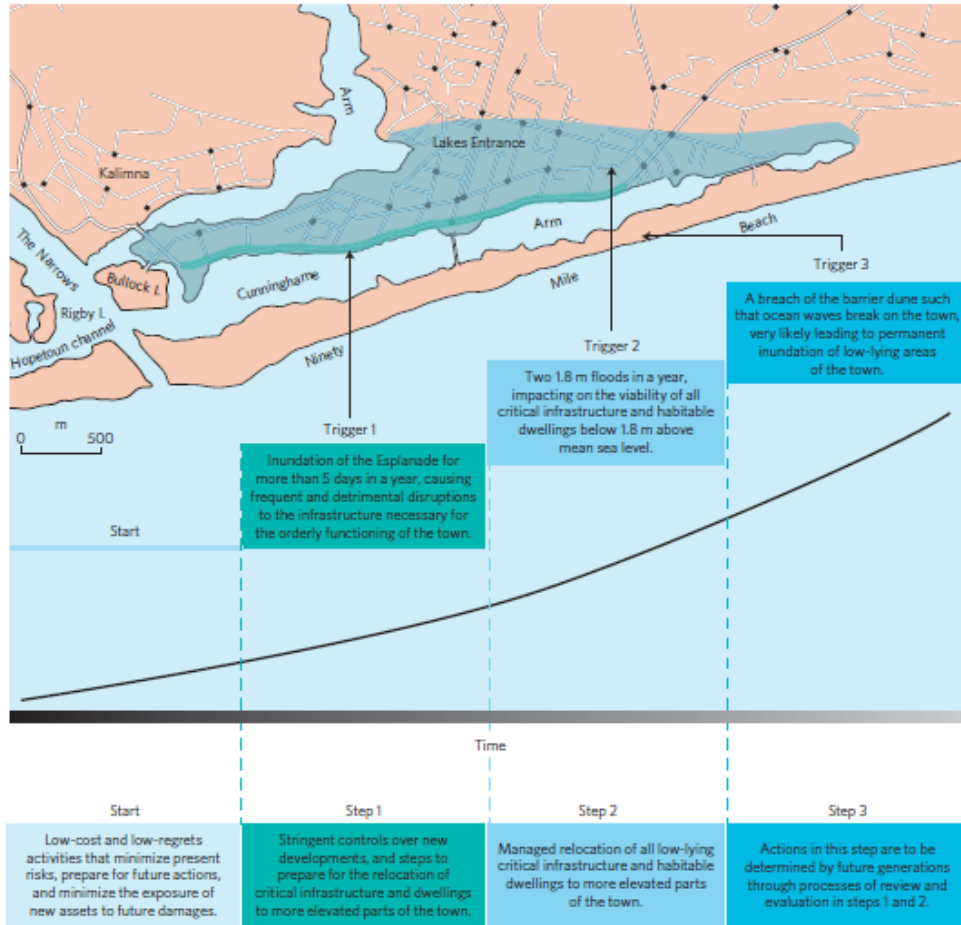



Multi-Layered Safety in the Netherlands



Vulnerability of the Netherlands to flooding



Below sea-level:

- Approximately 9 million people and 70% of GDP
- 60% of the land
- Amsterdam, Rotterdam, and Schiphol Airport

Flooding along the Rhine and Meuse rivers

Area potentially flooded at water level 0.0 m MSL



The 1993 and 1995 high river discharges



Present flood defence system

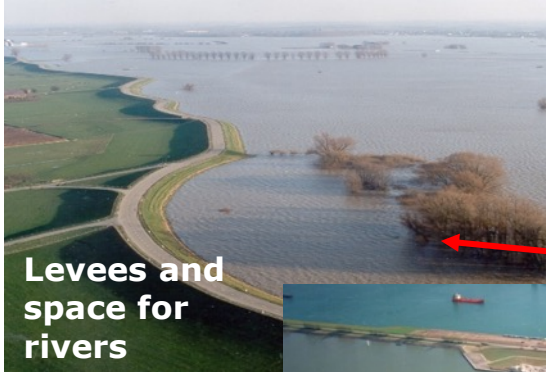



Multi-layer approach to flood risk management

Emergency management, evacuation

Sustainable, flood proof spatial
planning and building

Prevention of flooding; reduction of
probability of flooding





Principles of new flood protection policy

1. Provide a **basic level of safety** (up to 1 in 100,000 years) for every one behind dikes through risk mitigation measures in areas with large individual risk
2. Counteract **societal disruption**: provide additional protection for areas which will experience a large number of casualties or large economic damage in case of flooding
3. Establish **protection of vital and vulnerable infrastructure** to enhance the functioning of an area during and after a flood disaster.

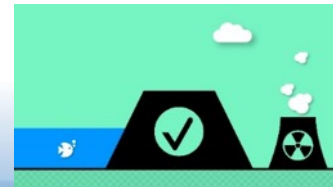
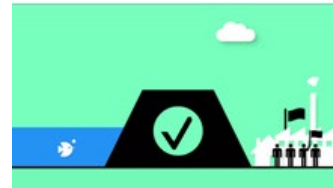
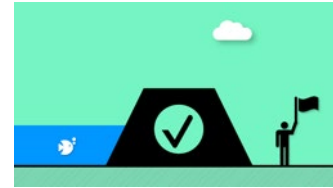



New flood protection standards



New standards based on a risk based approach

Deltares contributions: cost benefit and casualty risk analysis for embankments and dunes





Risk zoning for flood sensitive spatial planning

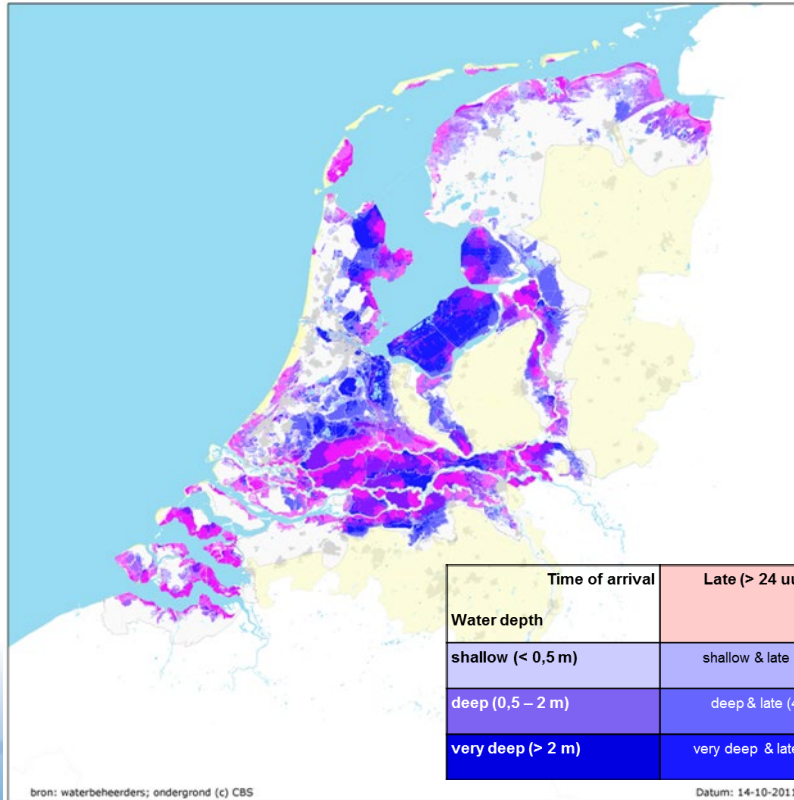

Time of arrival	Late (> 24 uur)	Early (6 – 24 uur)	Immediate (< 6 uur)
Water depth			
shallow (< 0,5 m)	shallow & late (1)	shallow & early (2)	shallow & immediate (3)
deep (0,5 – 2 m)	deep & late (4)	deep & early (5)	deep & immediate (6)
very deep (> 2 m)	very deep & late (7)	very deep & early (8)	very deep & immediate (9)

bron: waterbeheerders; ondergrond (c) CBS

Datum: 14-10-2011



Reducing consequences of flooding



Floating houses



Emergency management / evacuation



Waterproof exercise

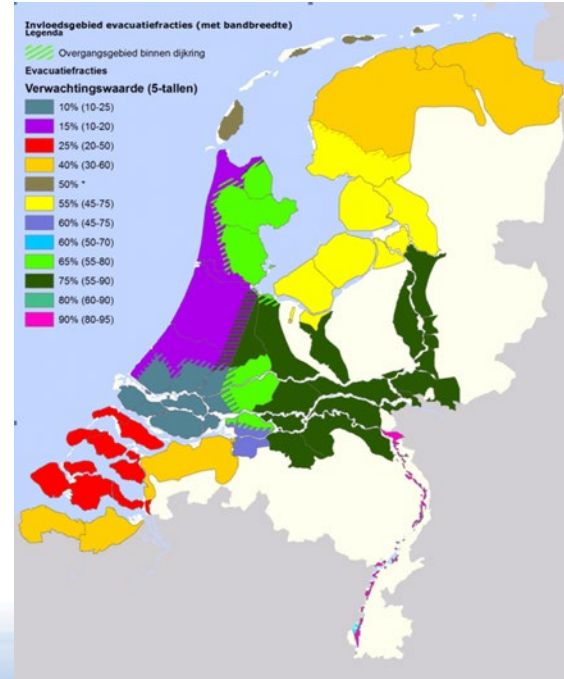

Evacuation percentages

Perception of responsibilities

Number

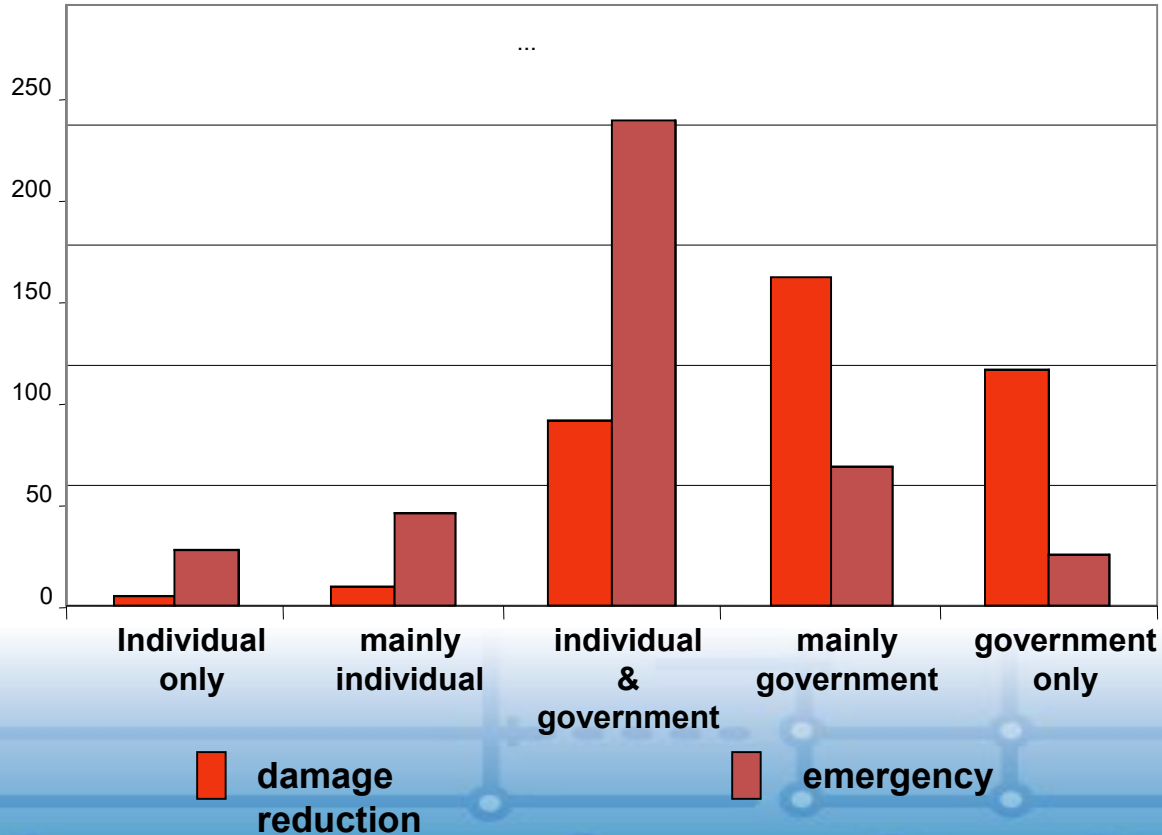

Measures to prepare for floods



Emergency kit

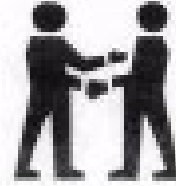

Appointments



Search for information



**Sand bags
flood boards**

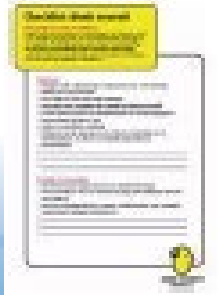

Emergency plan

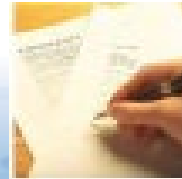

Insurance



Intention to take preparatory action

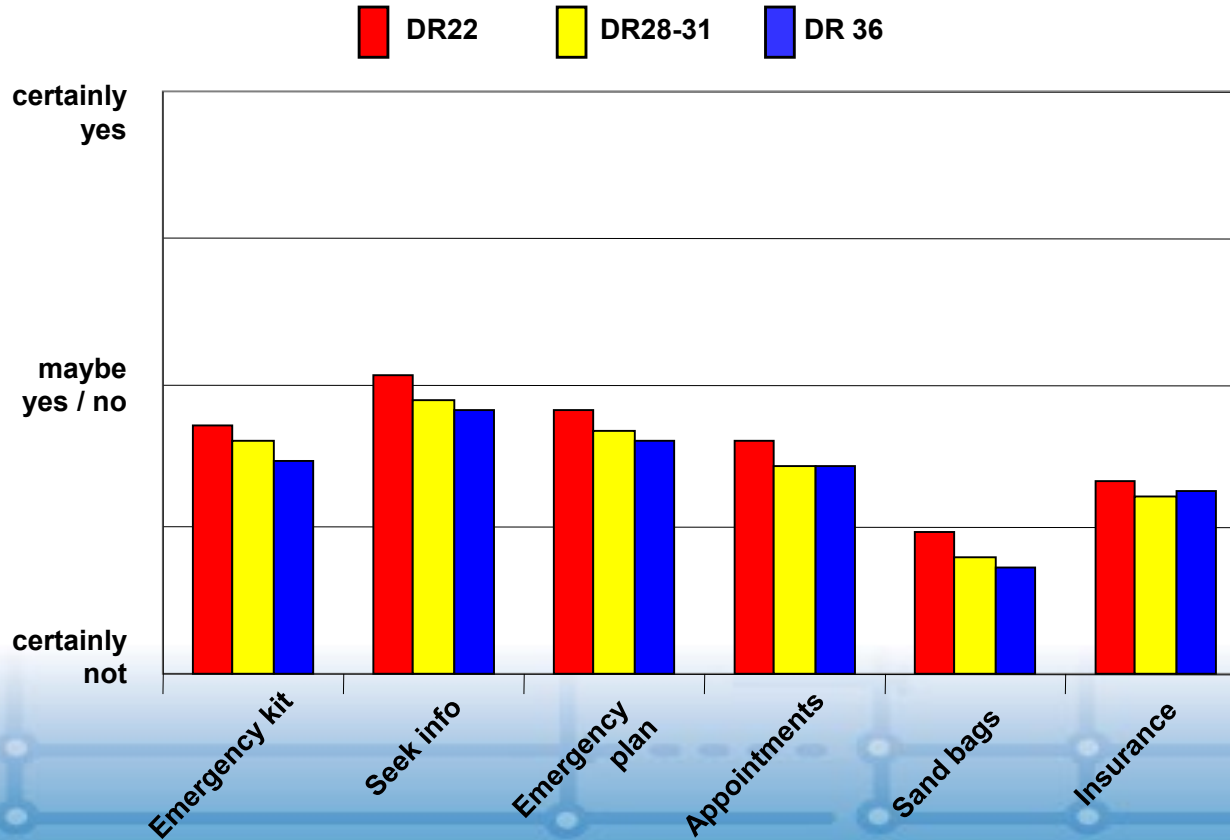



Summary of Dutch Flood Risk Policy

- Policy on flood risk management has been shaped in response to major flood disasters in the past
- Currently a more pro-active approach is adopted and implemented
- Prevention was and is the major priority in dealing with flood risk
- Growing attention for flood proof spatial planning and building as well as for emergency management
- Government policy to raise awareness of citizens to promote flood preparedness
 - Dutch citizens have a lot of trust in the flood protection system
 - Risk perception is low, as is the flood preparedness

Application of MLS in Dordrecht

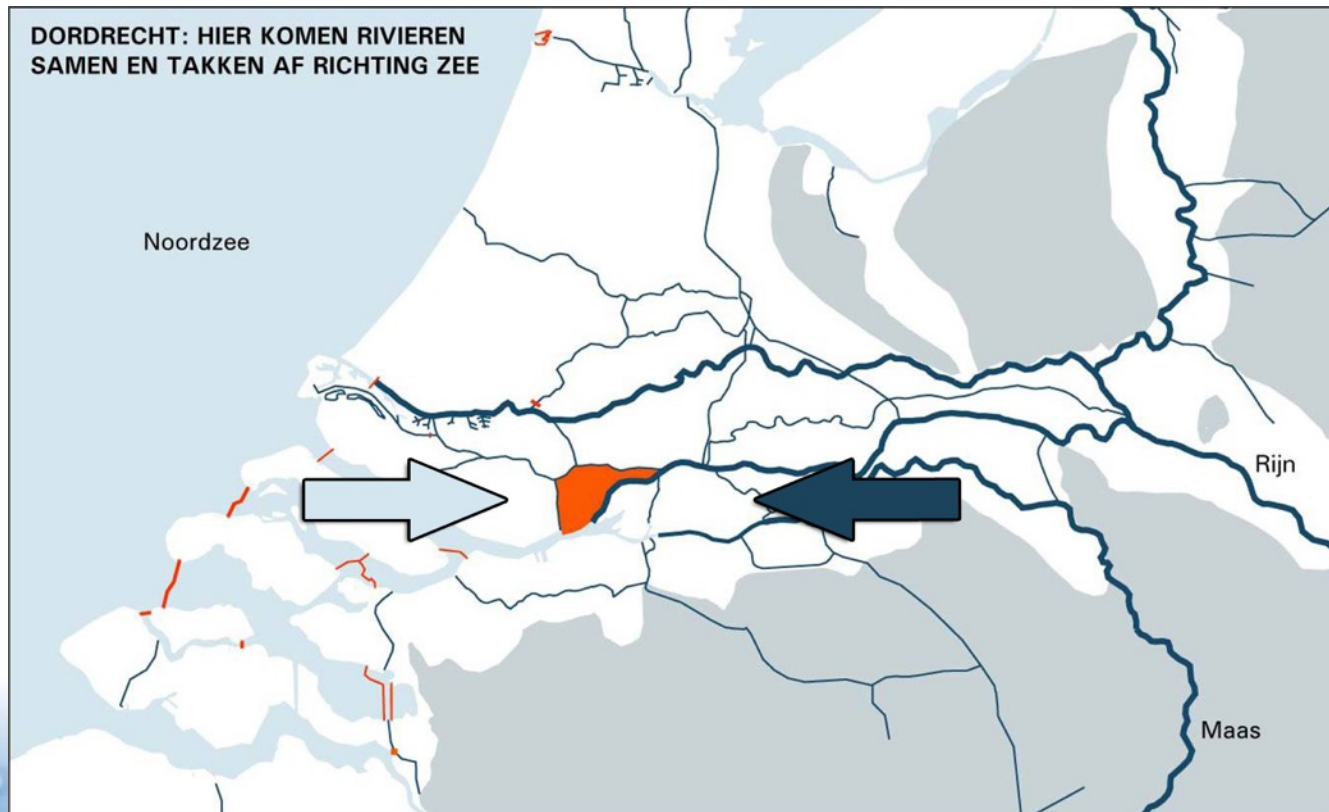

Island of Dordrecht

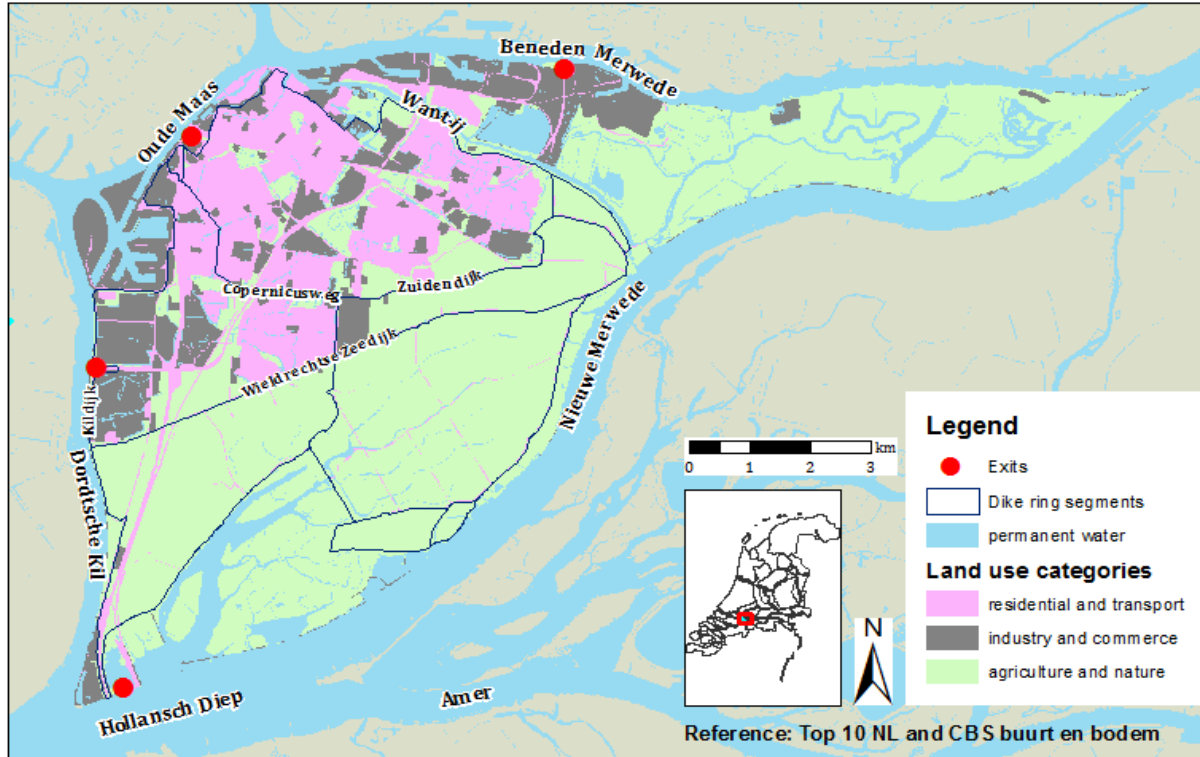

Profile:

- Urbanised low-lying island, partly protected by embankments
- Unprotected area consists of natural areas as well as urban/industrial areas

Vulnerable to:

- Extreme river discharges from the east
- Storm Surges from the west

Areas inside and outside dike ring 22 (1:2000)

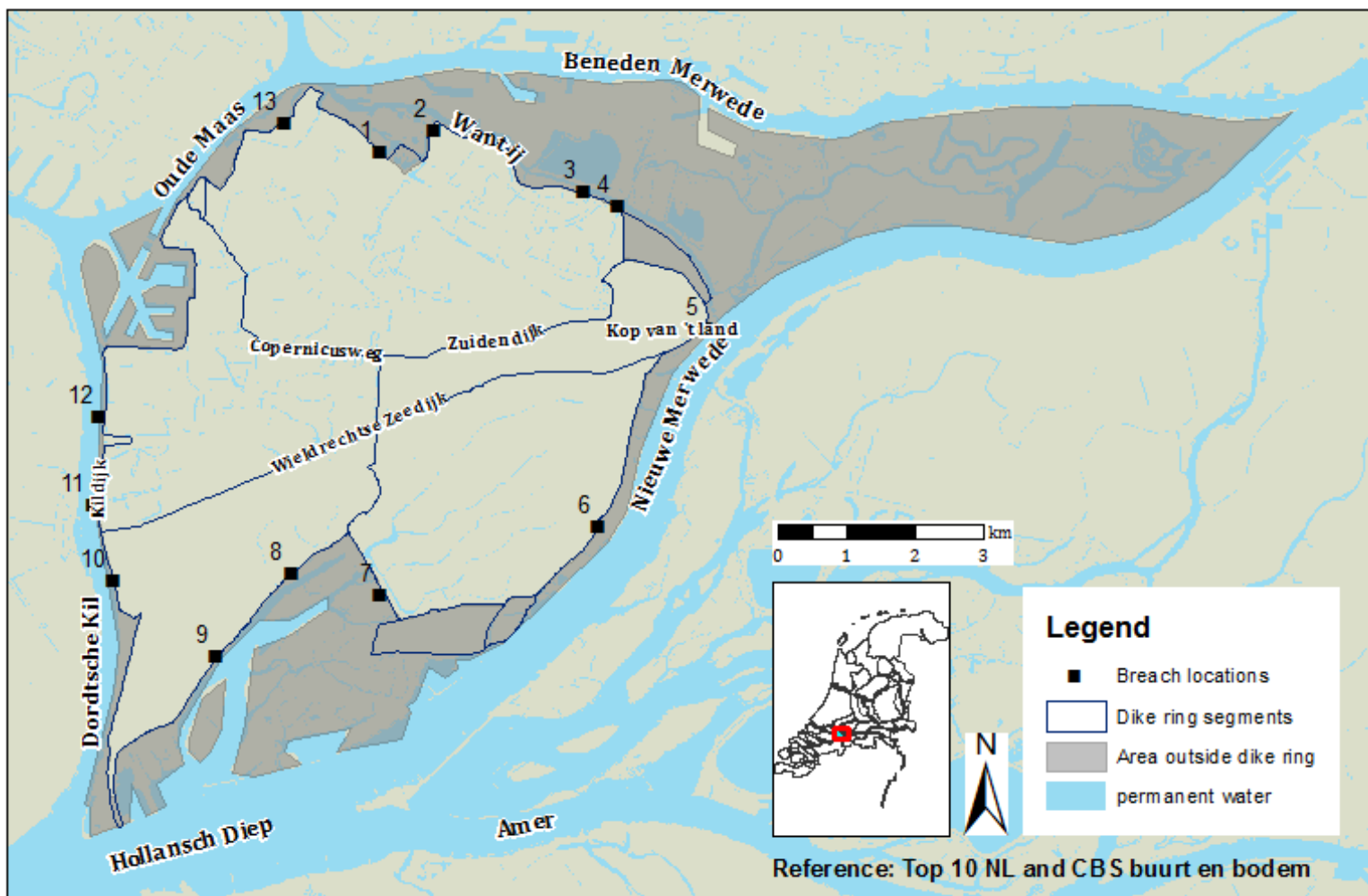



Flood Hazards

Level :

Inside: 0 to 0.8m + msl

Outside: 1.7 to 2.7 m + msl

Water levels:

Daily high tide: 1m + msl

1/10 year: 2.3m; 1/100: 2.6m

Flood protection standard: 1/2000 a year

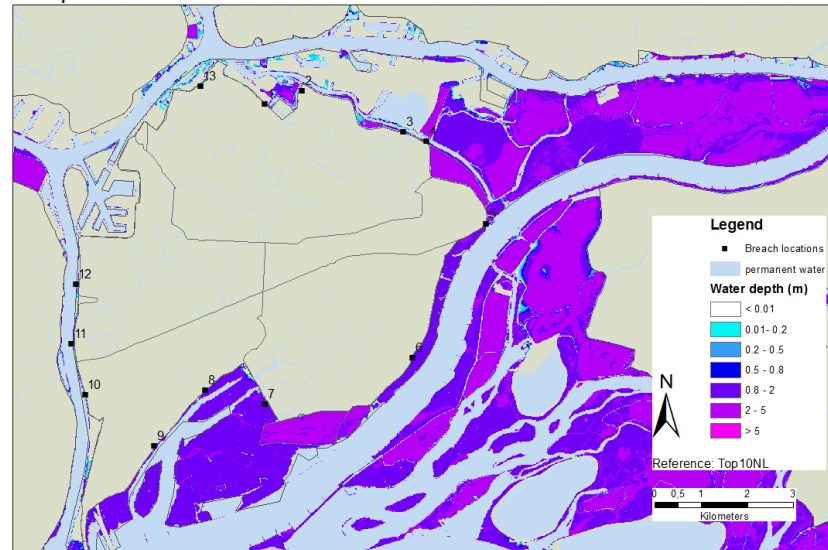
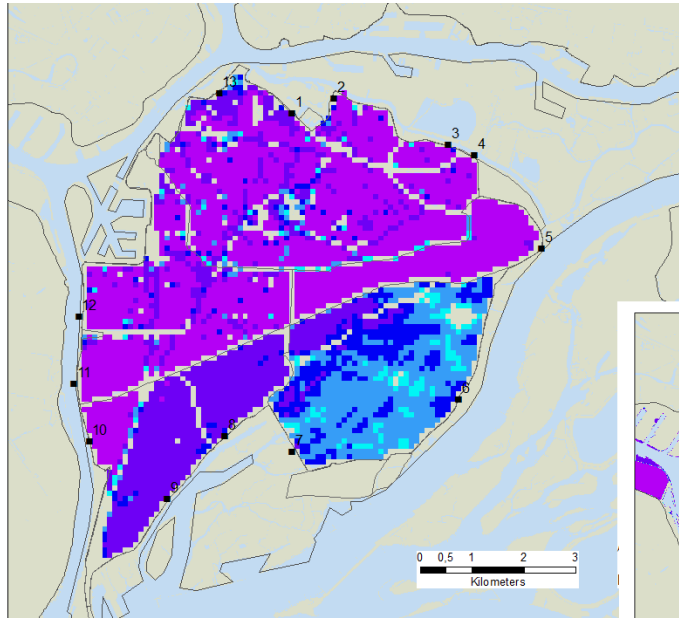

Outside embankments...





Inside embankments

Maximum water depth breach 5

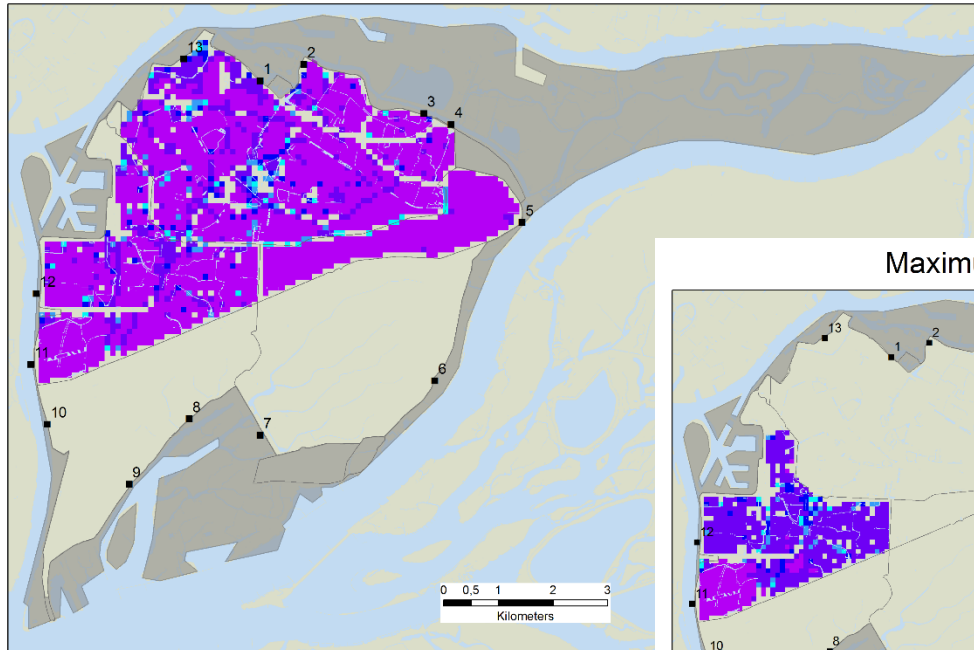

Maximum water depth breach 11

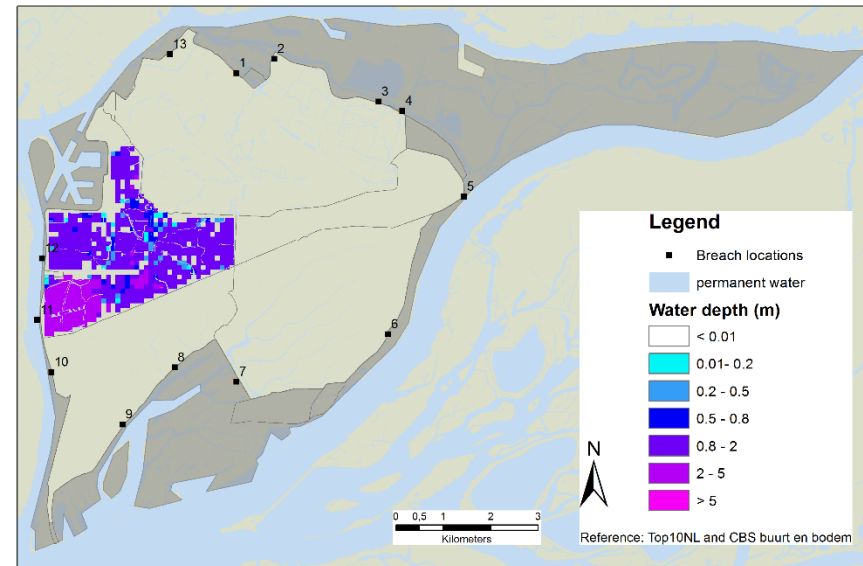



Multi-Layer Safety in Dordrecht



- ‘Unbreachable’ climate dike to the north
- Conventional dike in the south/west
- Schools and sports facilities provide additional southern buffer
- Existing old embankments are maintained to compartmentalize floods and limit extent
- Emergency management plan in place to manage first response (e.g. temporary barriers) and evacuation (<2 days)
- Recovery (breach repairs, pumping, cleaning, etc.) takes 3mth-1yr



Thank you

andrew.warren@deltares.nl

